



# TH

# 12.80



CONSTRUCTION



LOGISTICS



MINING &  
QUARRYING



EVENTS AND  
FILM

TH  
12.80



**CAB**

Best-in-class  
safety and visibility



**PERFORMANCE**

Unrivaled lifting  
performance



**LOAD LIVE DIAGRAM**

Two real-time dynamic  
load charts

# TH 12.80

## DIMENSIONS (ft and in)

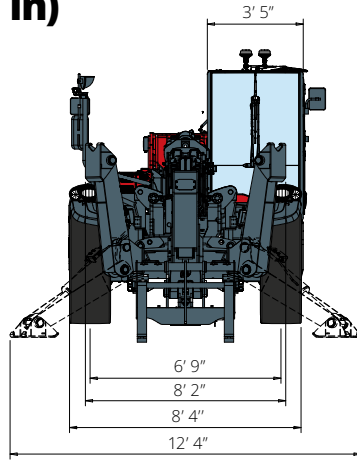

**FRONT**  
view

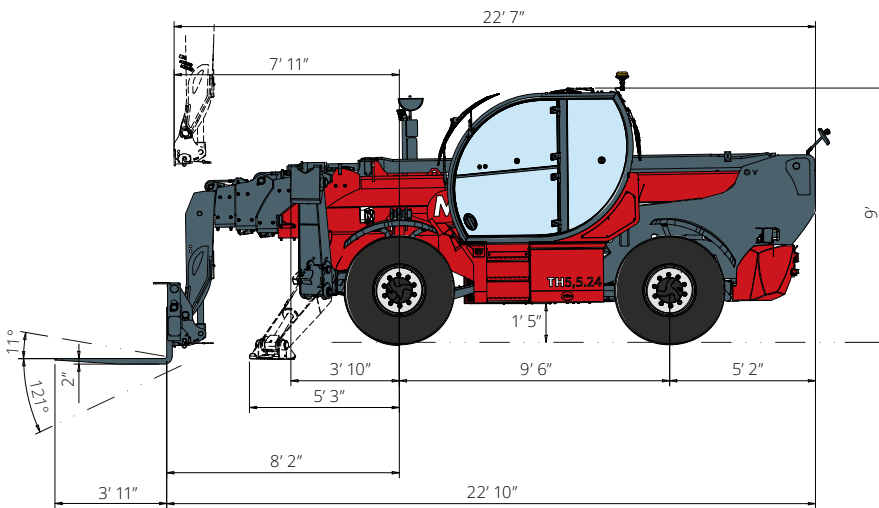

**SIDE**  
view

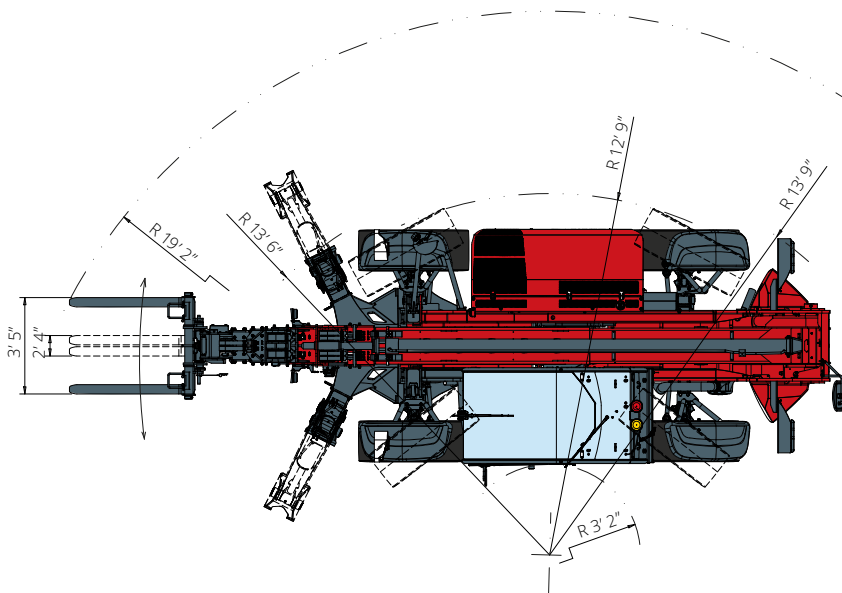

**TOP**  
view



Load chart with  
**FORKS AND OSCILLATING AXLE**

ATT-03-040

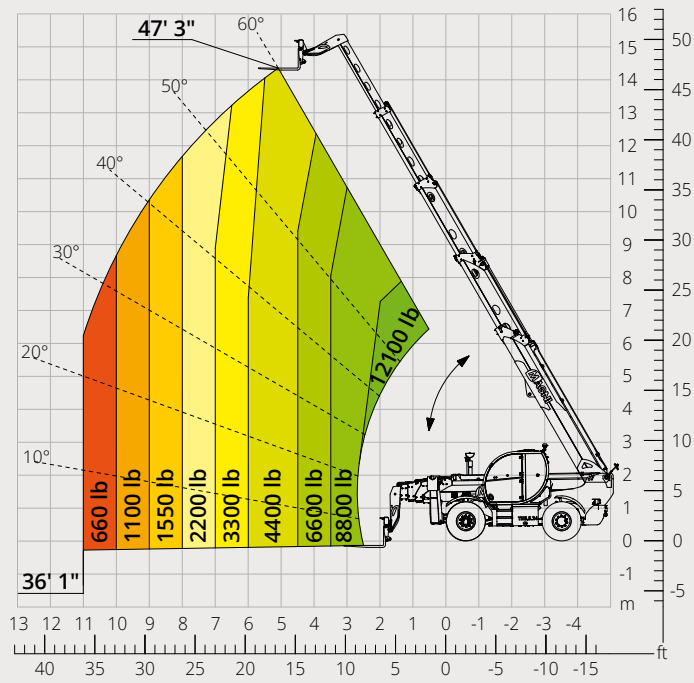

Load chart with  
**HOOK, 13,200 lb**

ATT-05-001

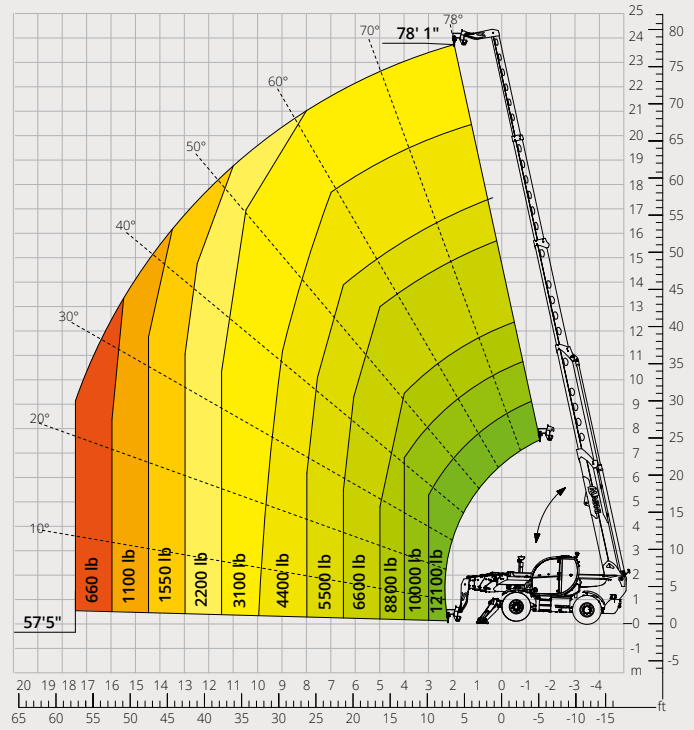

Load chart with  
**JIB, 4,400 lb**

ATT-04-013

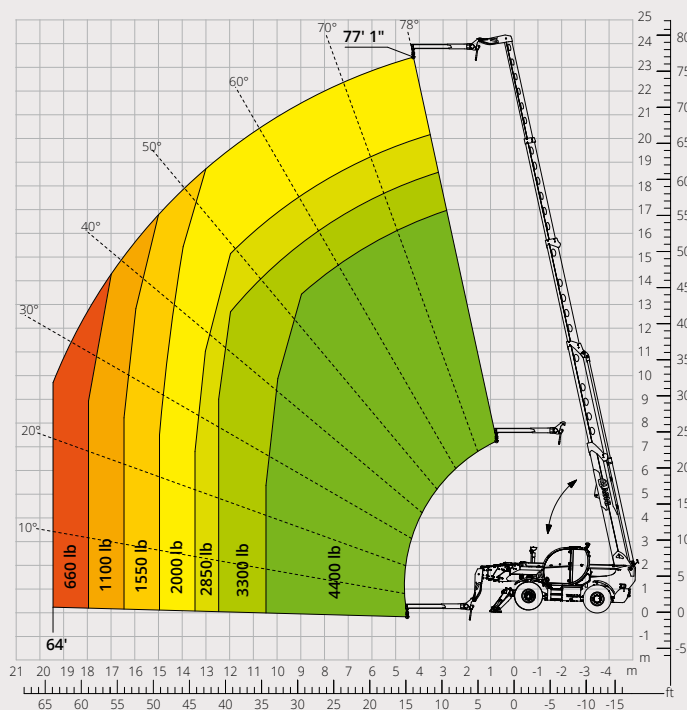

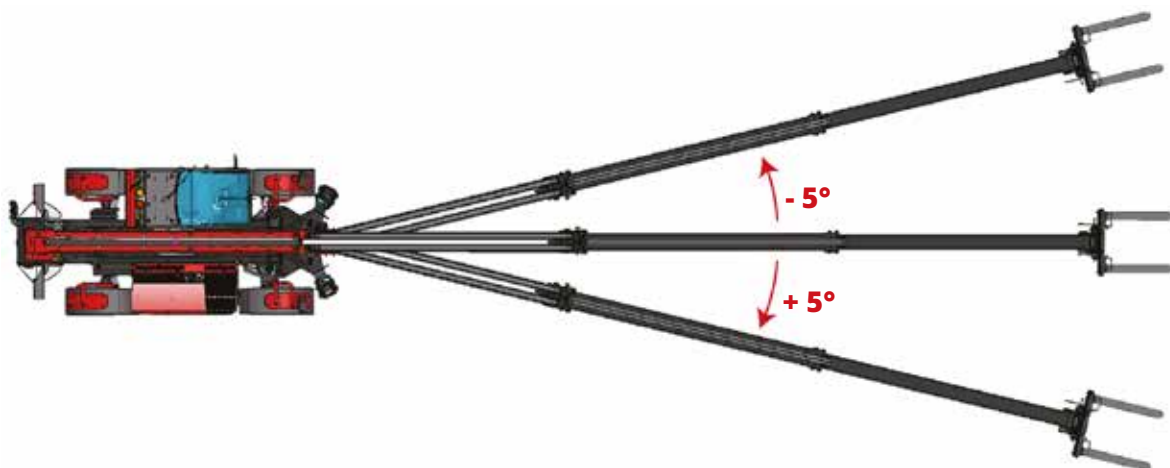

## LATERAL SHIFTING SYSTEM

This telehandler is equipped with a lateral shifting system that permits to move sideways the rear part of the chassis and, with it, the telescopic boom relative to the longitudinal axis of the machine to correct the load position without the need to move the machine.

This system, in fact, allow a shifting of  $\pm 5^\circ$  that corresponds to a shift of  $\pm 4' 11''$  with the boom completely extended, independently from which attachment is equipped.



<b>Machine model</b>	Telescopic handler	TH 12.80
	Maximum lifting capacity	12,100 lb
	Maximum lifting height	77' 9"
	Maximum reach	62' 8"
<b>Stabilizers</b>	Type	Pivoting
<b>Engine</b>	Model	<b>Deutz TCD 3,6 L4 EDG - Stage IIIA</b>   <b>Deutz TCD 3,6 L4 Stage V</b>
	Rated power	100 kW (136 hp) at 2,200 rpm
	Maximum torque	369 lb/ft at 1,600 rpm
	Displacement	219.7 in <sup>3</sup>
	Cylinders	4 in line
	Engine configuration	Turbocharged direct injection diesel
	Cooling system	Water – intercooler
<b>Transmission</b>	Type	Hydrostatic
	Maximum pressure	500 bar
	Gear box	Dropbox, 2 speeds forward-reverse
<b>Axles and brakes</b>	Type	Axles with planetary gearboxes
	Front axle	Oscillating and steering with levelling, +/-8°
	Rear axle	Oscillating and steering with hydraulic lock
	No. of driving/steering wheels	4WD - 4WS
	Steering mode	Frontal/Concentric/Crab
	Service brake	Wet multi-disk on front and rear axle
	Parking brake	Hydraulic with negative action on front axle
<b>Performance</b>	Tyres dimensions	445/65 R22.5
	Max. travel speed	25 mph
	Gradeability (unladen)	44%
	Turning radius (end of forks)	19'9"
<b>Weights</b>	Total unladen*	35,500 lb
<b>Tank and system capacities</b>	Fuel tank	39.6 U.S. gal
	AdBlue	2.64 U.S. gal
	Hydraulic oil tank	24.6 U.S. gal
	Engine oil tank	2.4 U.S. gal
	Cooling liquid	5.3 U.S. gal
<b>Hydraulic circuit for movements</b>	Circuit type	Load sensing
	Service pump	Variable displacement
	Max. hydraulic flow rate	27.7 U.S. gpm
	Max. boom head flow rate	19.8 U.S. gpm
	Max. operating system pressure	350 bar
	Controls for boom movements	SIL 2 electro-proportional valve
<b>Standard met</b>	Movements control	1 joystick with integrated manoeuvre enable
		2006/42/EC: EU Machinery Directive
		2016/1628: EU Regulation on the emissions of stage V engines
		EN 1459-X: Relating to standards on the safety requirements for variable reach machines
		EN 280-1/EN 280-2: standards relating to mobile elevating work platforms (if available)
	ROPS/level 2 FOPS: relating to the standards for protective structures	

*The data given in this brochure are provided for information purposes and are subject to change without prior notice.  
All images are purely guideline and might not give an exact representation of the product.  
\*the stated weight refers to the vehicle unladen with standard equipment and may vary depending on the chosen configuration.*

## The standard machine configuration includes:

### CAB

- Comfort seat with adjustable headrest
- Adjustable steering column
- Analogue joypad
- Adjustable sunblind
- Heating
- Air conditioning
- FM/AM radio with USB and Bluetooth connectivity
- Ambient LED lights
- USB Type-A and Type-C (5 V) inputs

### REAL TIME INFORMATION

- Touchscreen, 7"
- MCTS – Magni Combi Touch System on-board software
- Automatic RFID tools recognition system
- LMI – Load Moment Indicator
- LLD – Live Load Diagram
- Onboard and remote integrated diagnostics

### TECHNICAL SPECIFICATIONS

- Q-Fit standard
- Provision for platform
- Advanced three-line CAN BUS system
- Automatic levelling system for outriggers
- Automatic front and rear wheel alignment
- Chassis sideshift system
- Automatic parking brake
- Mechanical battery cut-off in engine compartment
- Electrical system: 24 V – IP67

### SERVICE

- Warranty: 24 months/2,000 hours