

TH 11.25 P



MINING &
QUARRYING



CONSTRUCTION



LOGISTICS



TH 11.25 P



CAB

Best-in-class
safety and visibility



PERFORMANCE

Unrivaled lifting
performance



LOAD LIVE DIAGRAM

Two real-time dynamic
load charts

TH 11.25 P

DIMENSIONS (ft and in)

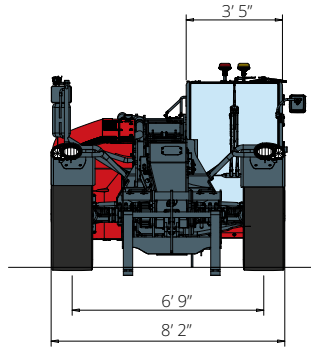

FRONT
view

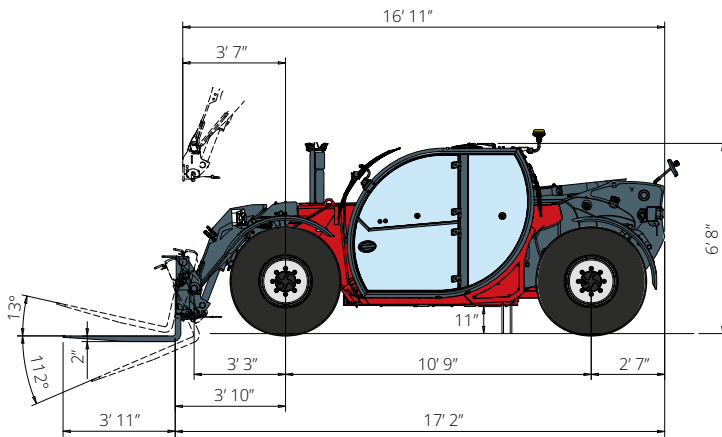

SIDE
view

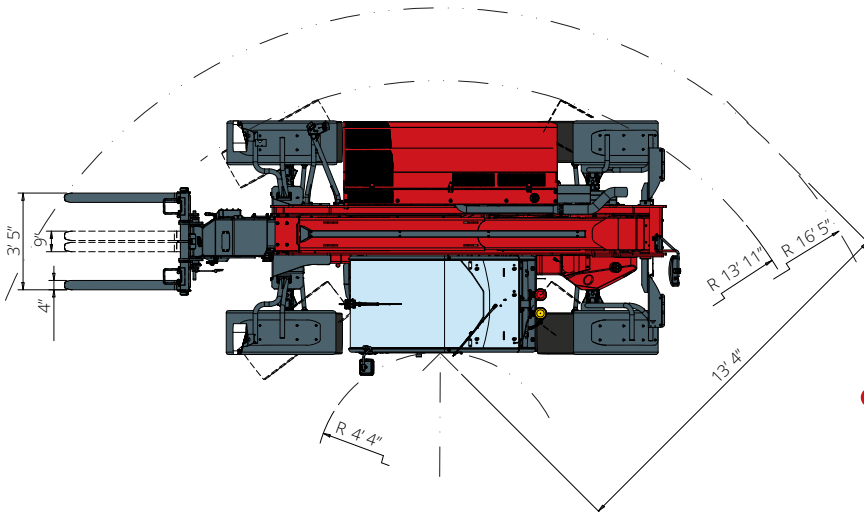

TOP
view

Load chart
FRONT ATTACHMENT ON TIRES

ATT-03-001

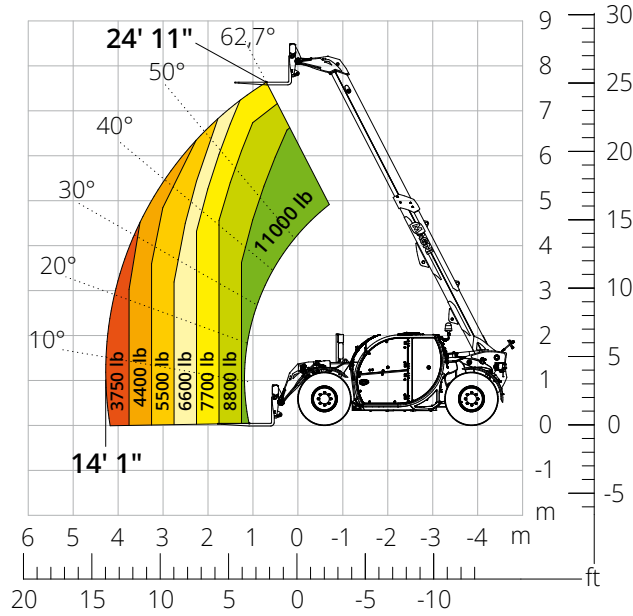

Load chart with
HOOK, 11,000 lb

ATT-05-014

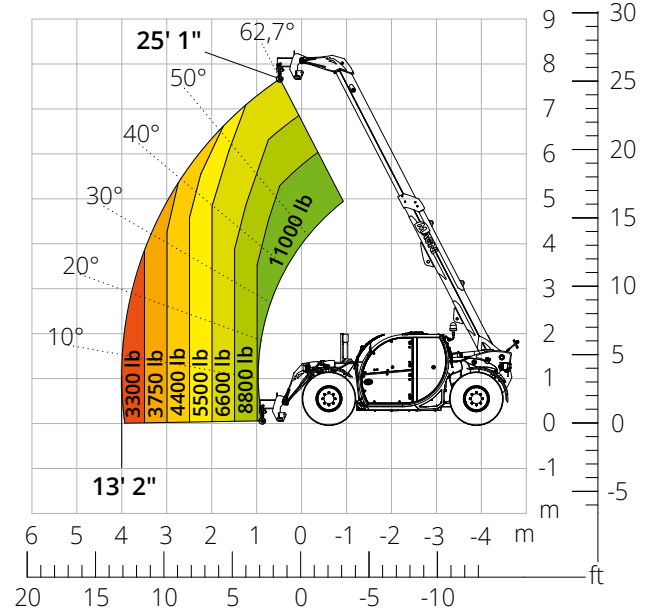

Load chart with
TELESCOPIC JIB, 5,500 lb - OPEN

ATT-04-021

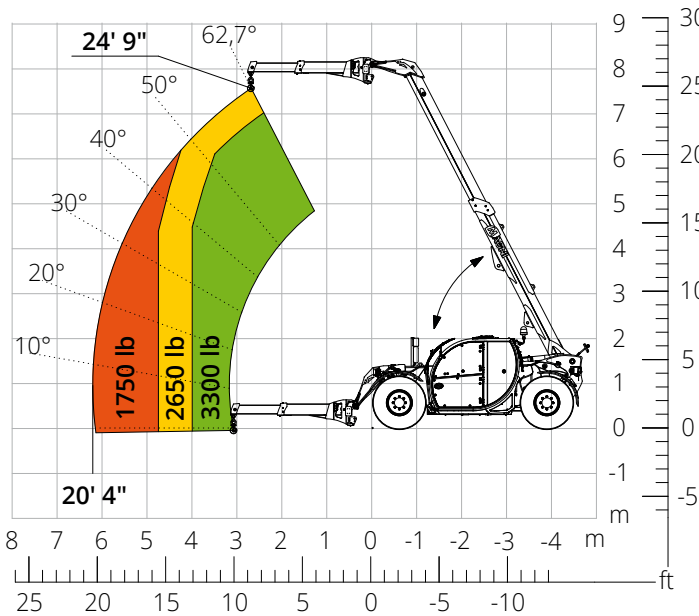

Load chart with
TELESCOPIC JIB, 5,500 lb - CLOSED

ATT-04-021

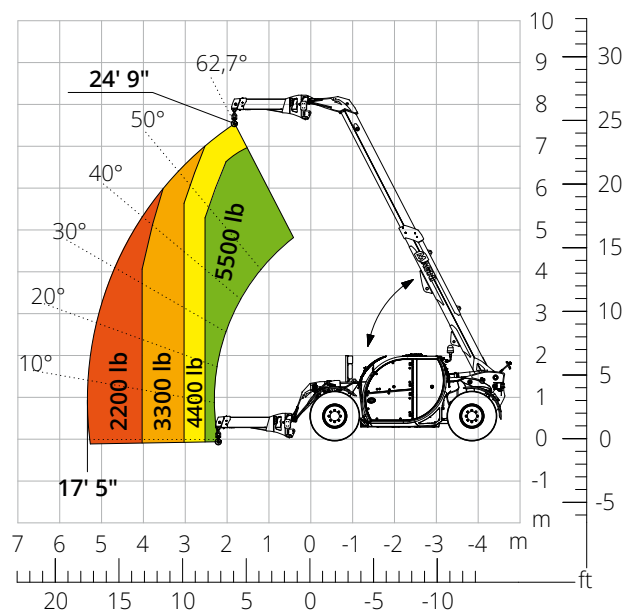

Load chart with
6,600 lb "SWAN NECK" JIB

ATT-04-023

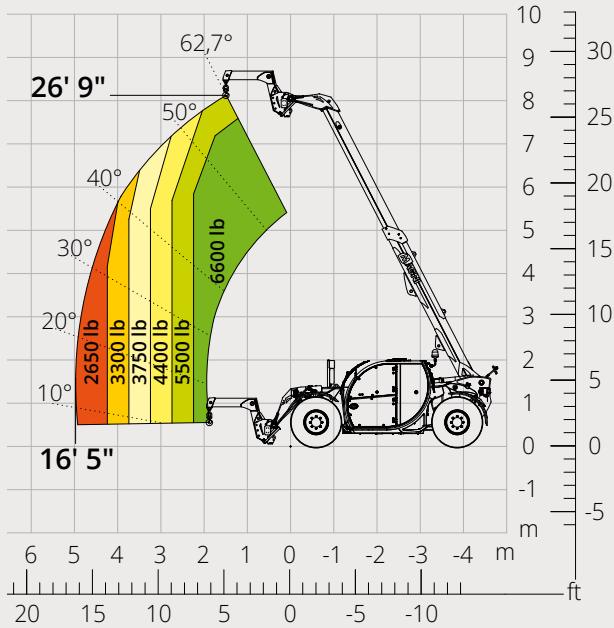

Load chart with
TYRE HANDLER, 5,500 lb

ATT-06-003

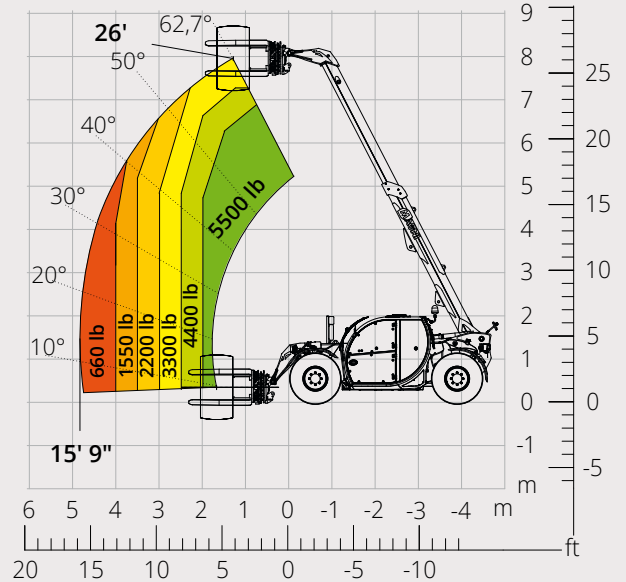

Load chart with
FIXED PLATFORM, 550 lb

ATT-01-001

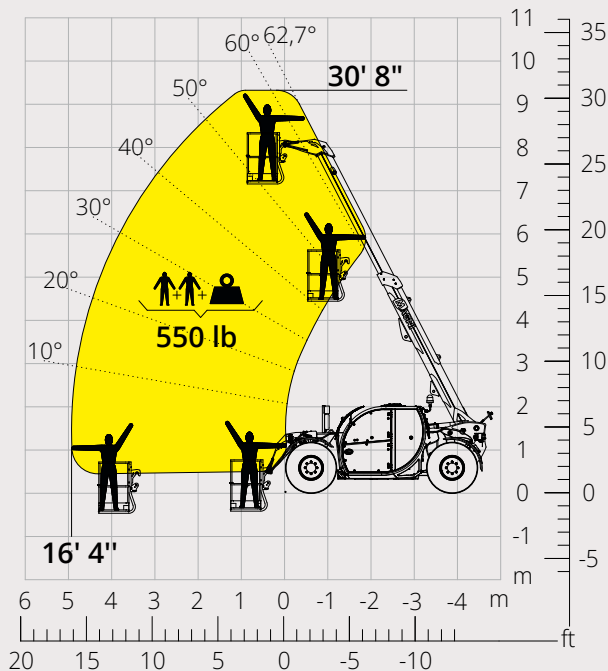

Load chart with
ROTATING EXTENDABLE PLATFORM, 550 lb

ATT-01-003

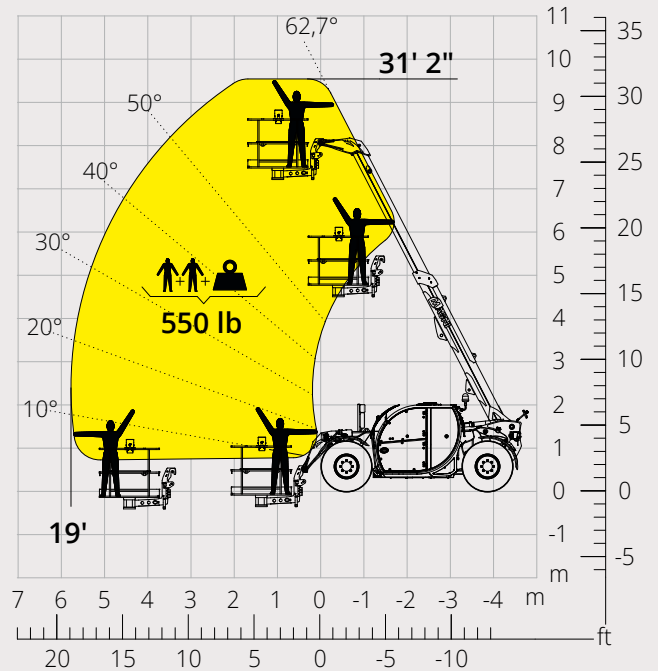

Load chart with
PLATFORM, 1,000 lb, FOR MINES

ATT-01-027

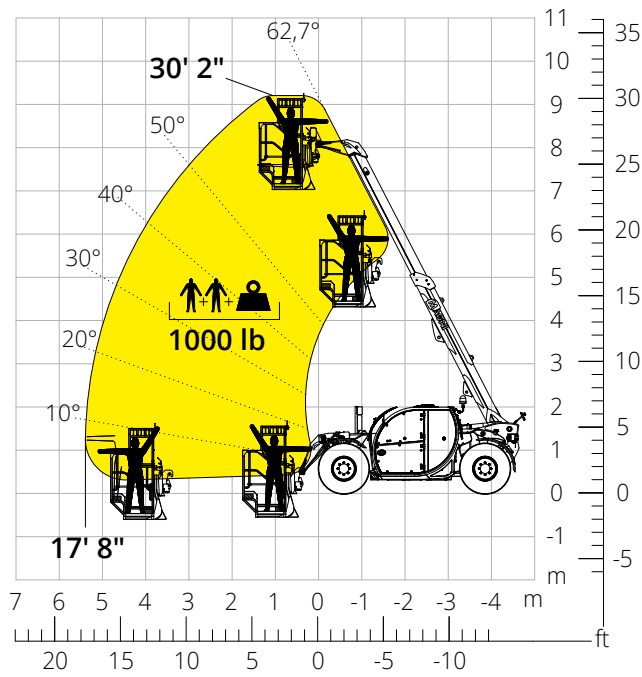

Machine model	Telescopic handler	TH 11.25 P	
	Maximum lifting capacity	11,000 lb	
	Maximum lifting height	24' 11"	
	Maximum reach	14' 1"	
Stabilizers	Type	-	
Engine	Model	Deutz TCD 3,6 L4 EDG Stage IIIA	Deutz TCD 3,6 L4 Stage V
	Rated power	74.4 kW (101.2 hp) at 2,200 rpm	
	Maximum torque	302 lb/ft at 1,600 rpm	
	Displacement	3.6 l	
	Cylinders	4 in line	
	Engine configuration	Turbocharged direct injection diesel	
	Cooling system	Water – intercooler	
Transmission	Type	Hydrostatic	
	Maximum pressure	530 bar	
	Gear box	Dropbox, 2 speeds forward-reverse	
Axles and brakes	Type	Axles with planetary gearboxes	
	Front axle	Steering	
	Rear axle	Free oscillation	
	No. of driving/steering wheels	4WD - 4WS	
	Steering mode	Frontal/Concentric/Crab	
	Service brake	Wet multi-disk on front and rear axle	
	Parking brake	Hydraulic with negative action on front axle	
Performance	Tyres dimensions	445/65 R22.5	
	Max. travel speed	21 mph	
	Gradeability (unladen)	53%	
	Turning radius (end of forks)	16'5"	
Weights	Total unladen*	17,600 lb	
Tank and system capacities	Fuel tank	39.6 U.S. gal	
	AdBlue	2.64 U.S. gal	
	Hydraulic oil tank	24.6 U.S. gal	
	Engine oil tank	2.4 U.S. gal	
	Cooling liquid	5.3 U.S. gal	
Hydraulic circuit for movements	Circuit type	Load sensing	
	Service pump	Variable displacement	
	Max. hydraulic flow rate	90 l/min	
	Max. boom head flow rate	75 l/min	
	Max. operating system pressure	225 bar	
	Controls for boom movements	SIL 2 electro-proportional valve	
Standard met	Movements control	1 joystick with integrated manoeuvre enable	
		2006/42/EC: EU Machinery Directive	
		2016/1628: EU Regulation on the emissions of stage V engines	
		EN 1459-X: Relating to standards on the safety requirements for variable reach machines	
		EN 280-1/EN 280-2: standards relating to mobile elevating work platforms (if available)	
	ROPS/level 2 FOPS: relating to the standards for protective structures		

*The data given in this brochure are provided for information purposes and are subject to change without prior notice.
All images are purely guideline and might not give an exact representation of the product.
the stated weight refers to the vehicle unladen with standard equipment and may vary depending on the chosen configuration.

The standard machine configuration includes:

CAB

- Comfort seat with adjustable headrest
- Adjustable steering column
- Analogue joypad
- Adjustable sunblind
- Heating
- Air conditioning
- FM/AM radio with USB and Bluetooth connectivity
- Ambient LED lights
- USB Type-A and Type-C (5 V) inputs

REAL TIME INFORMATION

- Touchscreen, 7"
- MCTS – Magni Combi Touch System on-board software
- Automatic RFID tools recognition system
- LMI – Load Moment Indicator
- LLD – Live Load Diagram
- Onboard and remote integrated diagnostics

TECHNICAL SPECIFICATIONS

- Q-Fit standard
- Advanced three-line CAN BUS system
- Automatic front and rear wheel alignment
- Automatic parking brake
- Mechanical battery cut-off in engine compartment
- Electrical system: 24 V – IP67

SERVICE

- Warranty: 24 months/2,000 hours