

TH

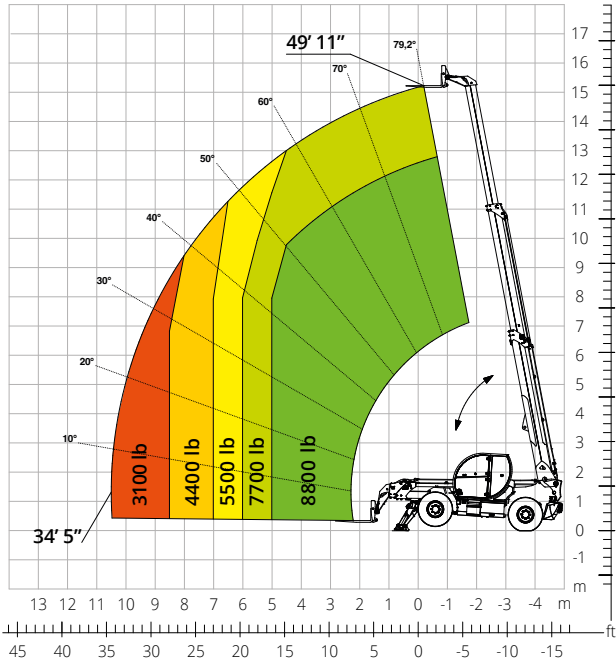

9.50 SP

PRELIMINARY



Load chart on stabilizers



CONSTRUCTION



LOGISTICS

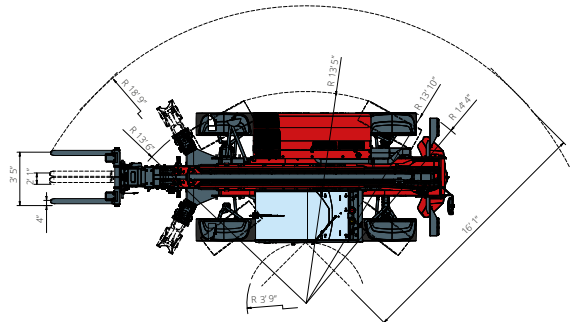
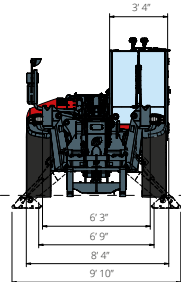
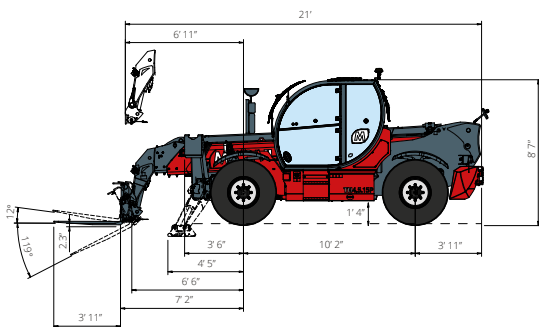

Machine model	Telescopic handler	TH 9.50 SP	
	Maximum lifting capacity	8,800 lb	
	Maximum lifting height	49' 11"	
	Maximum reach	34' 5"	
Stabilisers	Type	Pivoting	
Engine	Model	Deutz TCD 3,6 L4 EDG Stage IIIA	Deutz TCD 3,6 L4 Stage V
	Rated power	74.4 kW (101.2 hp) at 2,200 rpm	
	Maximum torque	302 lb/ft at 1,600 rpm	
	Displacement	219.7 in ³	
	Cylinders	4 in line	
	Engine type	Turbocharged direct injection diesel	
	Cooling system	Water – intercooler	
Transmission	Type	Hydrostatic	
	Maximum pressure	530 bar	
	Gearbox	Dropbox, 2 speeds forward-reverse	
Axles and brakes	Type	Axles with planetary gearboxes	
	Front axle	Oscillating and steering with levelling, +/-8°	
	Rear axle	Free oscillation	
	No. of driving - steering wheels	4WD - 4WS	
	Steering mode	Frontal/Concentric/Crab	
	Service brake	Wet multi-disk on front and rear axle	
	Parking brake	Hydraulic with negative action on front axle	
Performance	Tyre sizes	445/65 R22,5	
	Max. travel speed	21 mph	
	Gradeability (unladen)	61%	
	Turning radius (end of forks)	18'10"	
Weights	Total unladen*	26,900 lb	
Tank and system capacities	Diesel fuel	52.8 U.S. gal	
	AdBlue	2.64 U.S. gal	
	Hydraulic fluid	24.6 U.S. gal	
	Engine oil	2.4 U.S. gal	
	Coolant	5.3 U.S. gal	
Hydraulic circuit for movements	Circuit type	Gear pump	
	Service pump	Fixed displacement	
	Max. hydraulic flow rate	23.7 U.S. gpm	
	Max. boom head flow rate	18.5 U.S. gpm (OPT)	
	Max. operating system pressure	280 bar	
	Controls for boom movements	Electro-proportional valve	
Standard met	Movements control	1 joystick with integrated manoeuvre enable	
		2006/42/EC: EU Machinery Directive 2016/1628: EU Regulation on the emissions of stage V engines EN 1459-X: relating to standards on the safety requirements for variable-reach trucks ROPS/level 2 FOPS: relating to the standards for protective structures	

The data given in this brochure are provided for information purposes and are subject to change without prior notice. All images are purely guideline and might not give an exact representation of the product.

*the stated weight refers to the vehicle unladen with standard equipment and may vary depending on the chosen configuration.