

RTH 11.75



CONSTRUCTION



LOGISTICS

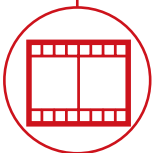

EVENTS AND
FILM



RTH
11.75



CAB

Best-in-class
safety and visibility



PERFORMANCE

Unrivaled lifting
performance



LOAD LIVE DIAGRAM

Three real-time dynamic
load charts

RTH 11.75

DIMENSIONS (ft and in)

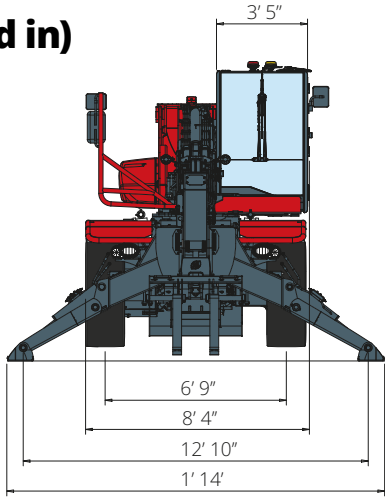

FRONT
view

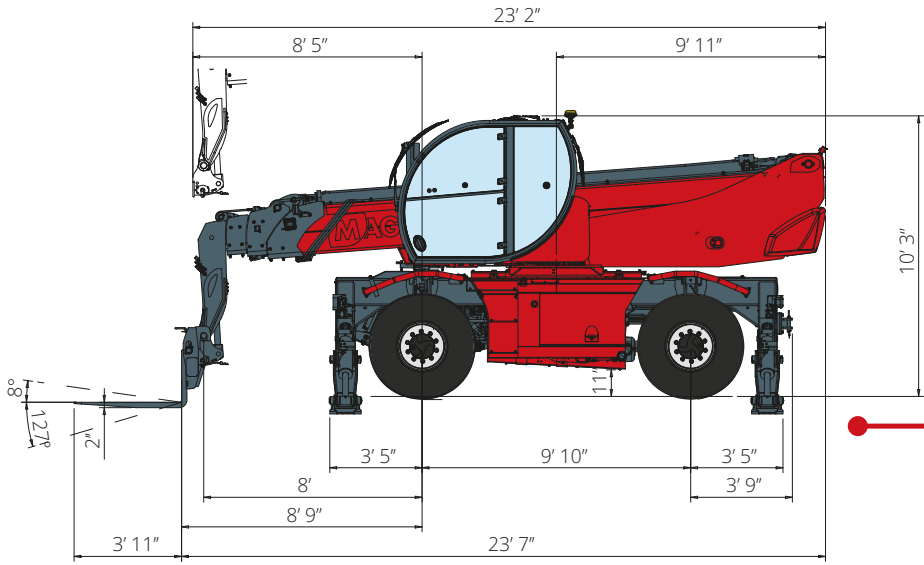

SIDE
view

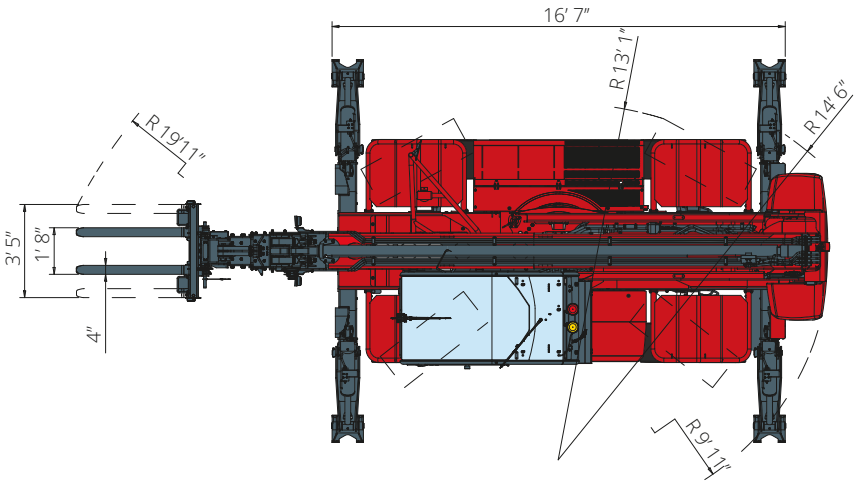

TOP
view

Load chart with
FULLY EXTENDED STABILIZERS (360°)

ATT - 03 - 001

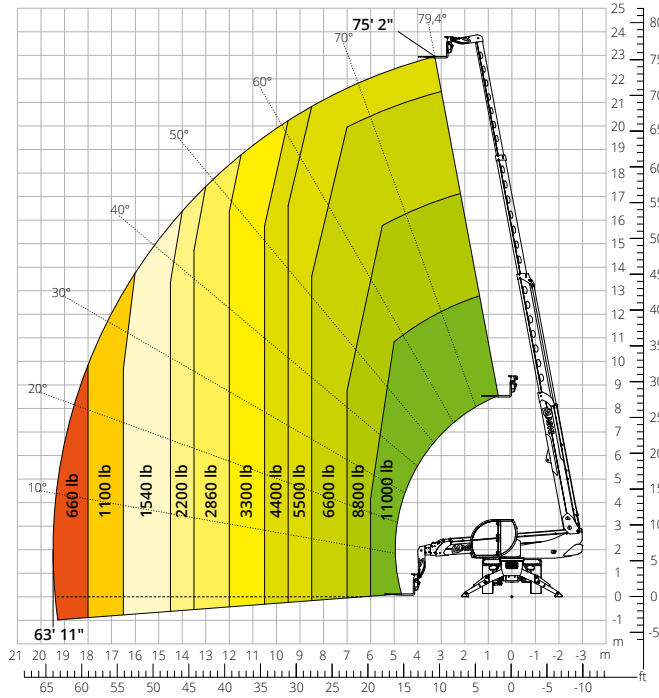

Load chart
FRONT ATTACHMENT ON TIRES

ATT - 03 - 001

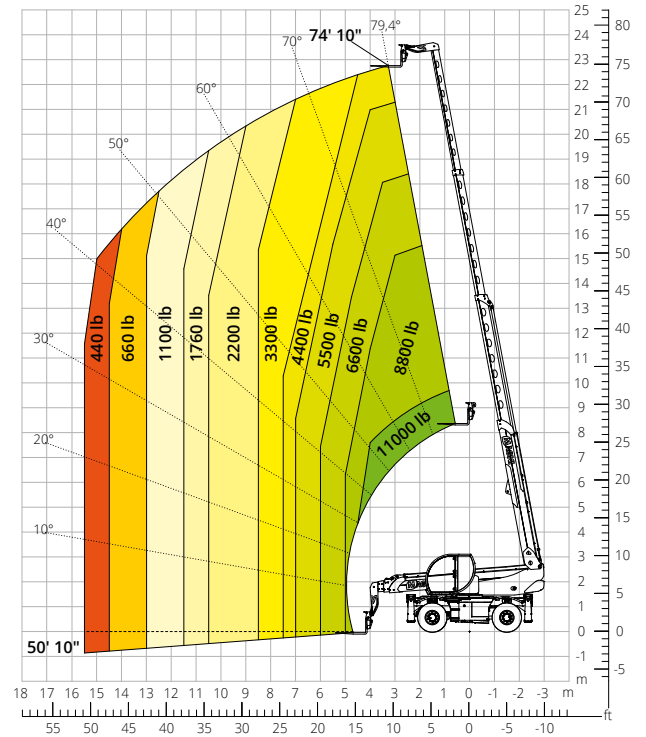

Load chart with
WINCH 7,700 lb

ATT - 02 - 002

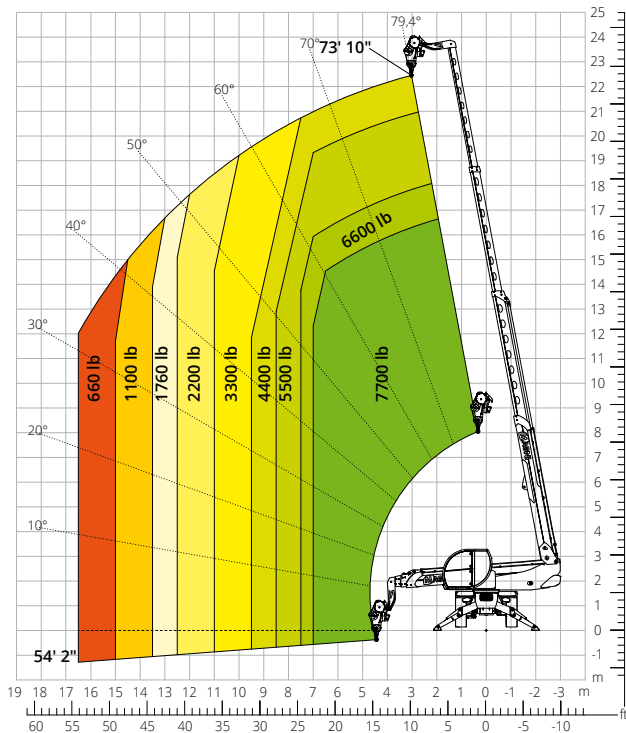

Load chart with
WINCH 11,000 lb

ATT - 02 - 019

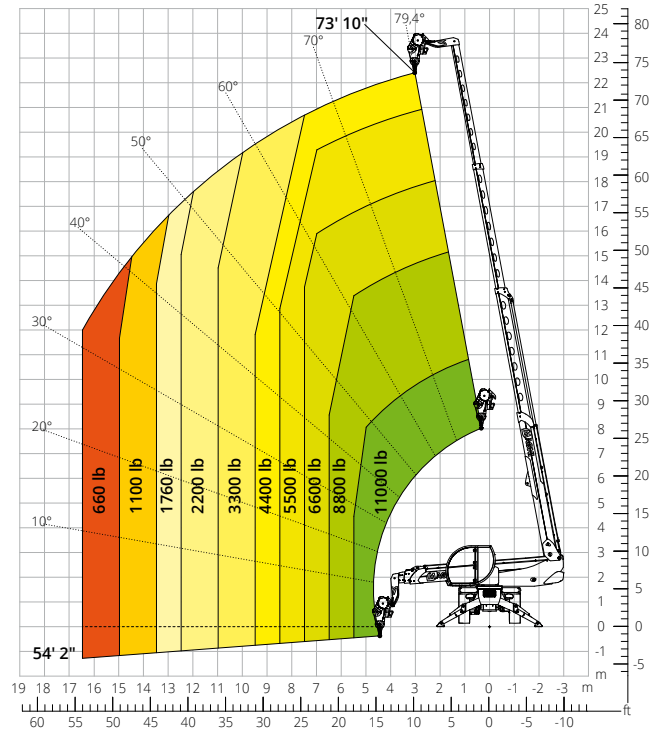

Load chart with
JIB WITH WINCH 1,760 lb

ATT - 04 - 005

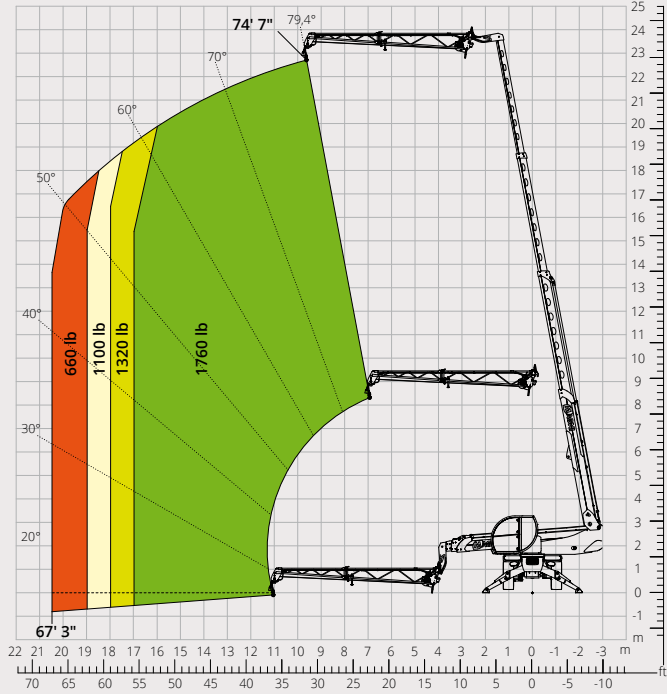

Load chart with
JIB WITH WINCH 3,300 lb

ATT - 04 - 011

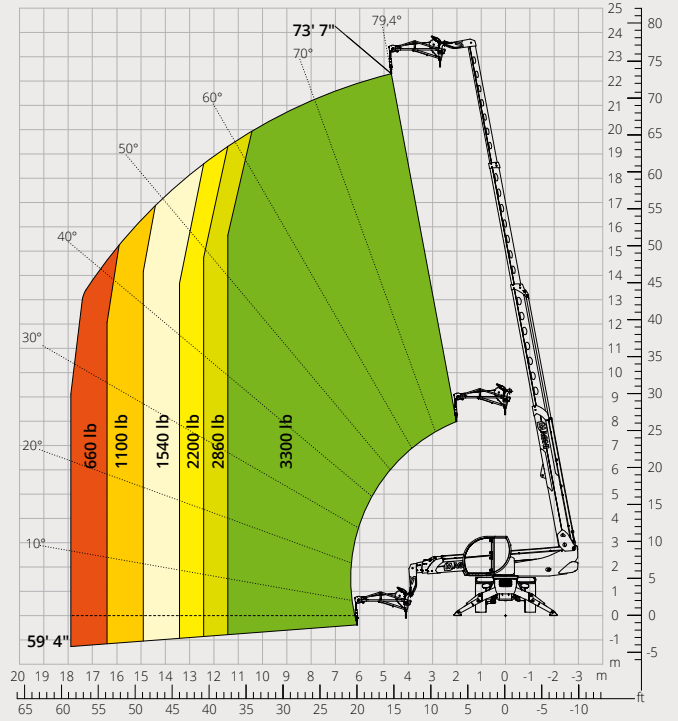

Load chart with
JIB WITH WINCH 4,400 lb

ATT - 04 - 015

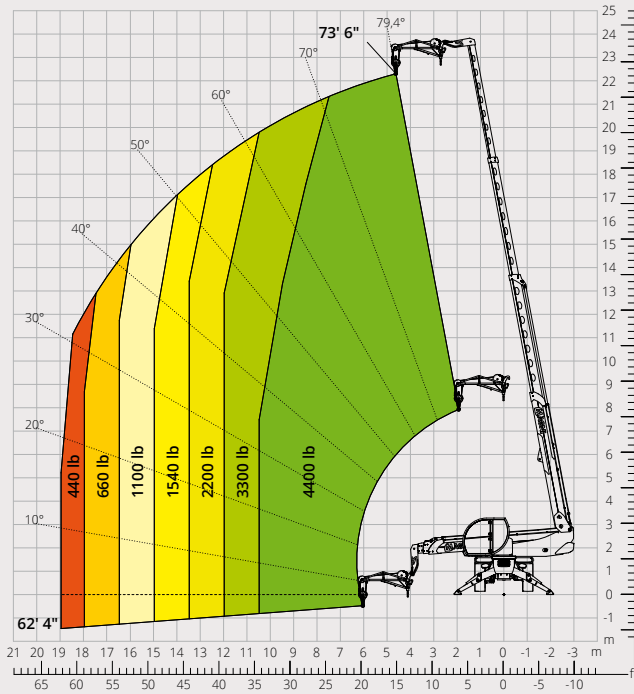

Load chart with
JIB, 1,300 lb

ATT - 04 - 001

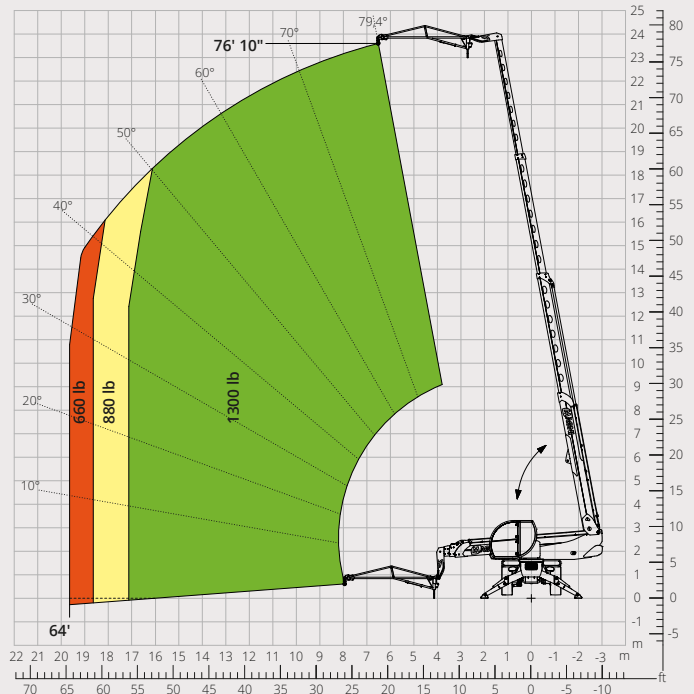

Load chart with
HOOK 11,000 lb
ATT - 05 - 014

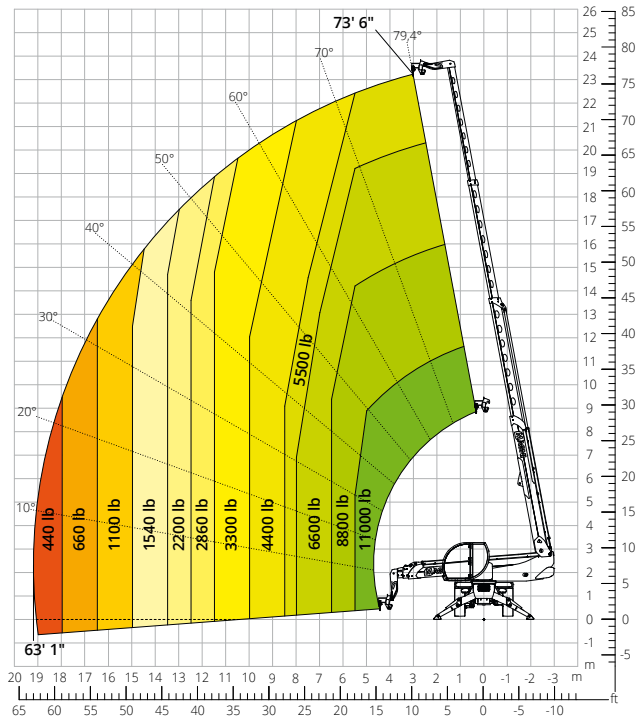

Load chart with
ROTATING EXTENDABLE PLATFORM 1,100 lb
ATT - 01 - 005

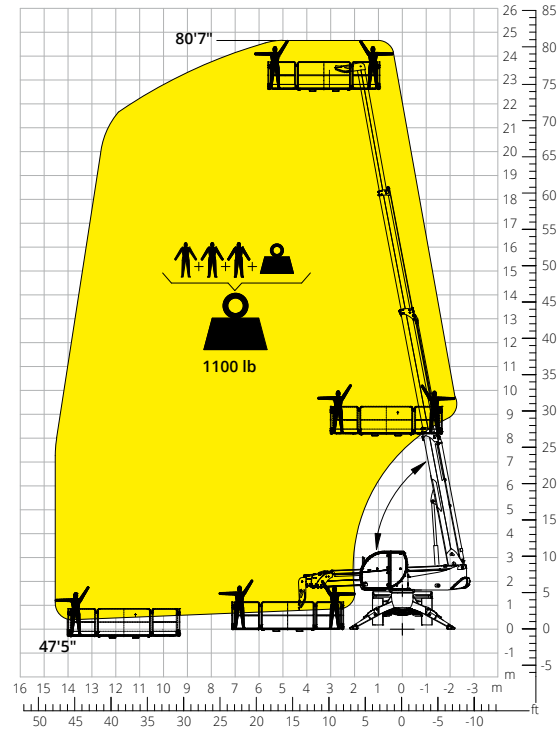

Load chart with
ROTATING EXTENDABLE PLATFORM 2,200 lb
ATT - 01 - 016

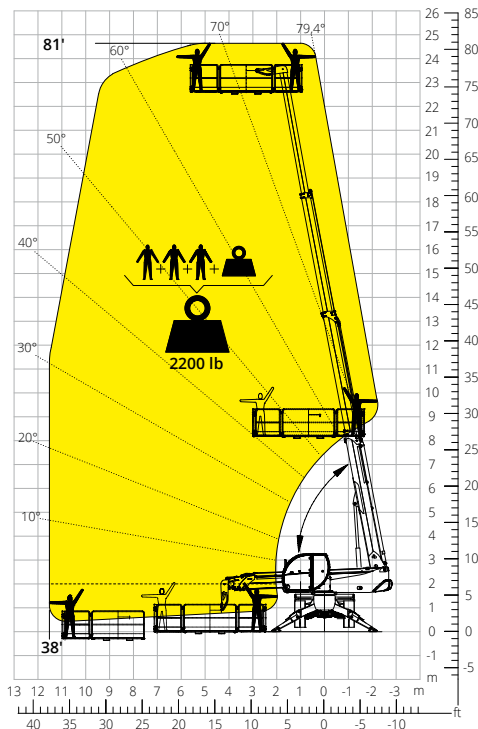

Load chart with
PLATFORM 1,100 lb WITH WINCH 1,300 lb
ATT-01-026

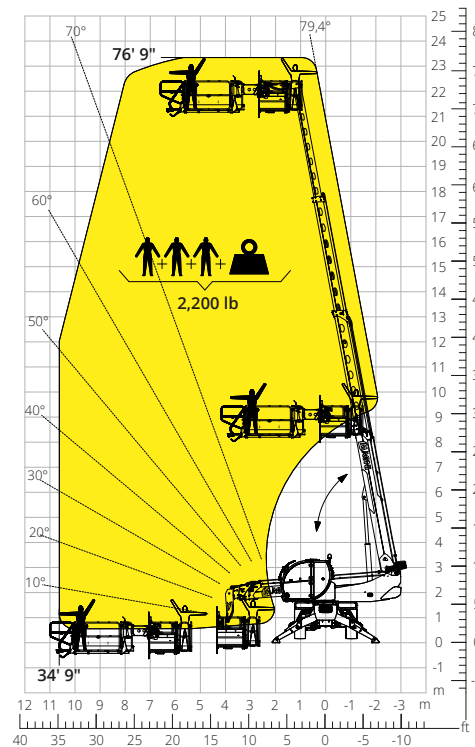

Machine model	Rotating telescopic handler	RTH 11.75	
	Maximum lifting capacity	11,000 lb	
	Maximum lifting height	75' 2"	
	Maximum reach	63' 11"	
	Rotation	360° (continuous)	
Stabilizers	Type	Pivoting	
Engine	Model	Deutz TCD 3,6 L4 EDG Stage IIIA	Deutz TCD 3,6 L4 Stage V
	Rated power	100 kW (136 hp) at 2,200 rpm	
	Maximum torque	369 lb/ft at 1,600 rpm	369 lb/ft at 1,600 rpm
	Displacement	220 in ³	
	Cylinders	4 in line	
	Engine type	Turbocharged direct injection diesel	
	Cooling system	Water - intercooler	
Transmission	Type	Hydrostatic	
	Maximum pressure	480 bar	
	Gearbox	Dropbox, 2 speeds forward-reverse	
Axles and brakes	Type	Axles with planetary gearboxes	
	Front axle	Oscillating and steering with levelling, +/-8°	
	Rear axle	Oscillating and steering with hydraulic lock	
	No. of steering wheels	4WD - 4WS	
	Steering mode	Frontal/Concentric/Crab	
	Service brake	Wet multi-disk on front and rear axle	
	Parking brake	Hydraulic with negative action on front axle	
Performance	Tyre sizes	445/65 R22.5	
	Max. travel speed	25 mph	
	Gradeability (unladen)	43%	
	Turning radius (at forks)	19' 11"	
Weights	Total unladen*	36,150 lb	
Tank and system capacities	Diesel fuel	46.2 U.S. gal	46.2 U.S. gal
	AdBlue	-	2.64 U.S. gal
	Hydraulic fluid	28.3 U.S. gal	28.3 U.S. gal
	Engine oil	2.4 U.S. gal	2.4 U.S. gal
	Coolant	5.3 U.S. gal	5.3 U.S. gal
Hydraulic circuit for movements	Circuit type	Load sensing	
	Service pump	Variable displacement	
	Max. hydraulic flow rate	28 U.S. gpm	
	Max. boom head flow rate	20 U.S. gpm	
	Max. working pressure	350 bar	
	Distributor for boom and turret movements	SIL 2 electro-proportional valve	
Standards met	Movements control	Dual joystick with integrated manoeuvre enable	
	2006/42/EC: EU Machinery Directive		
	2016/1628: EU Regulation on the emissions of stage V engines		
	EN 1459-X: Relating to standards on the safety requirements for variable reach machines		
	EN 280-1/EN 280-2: standards relating to mobile elevating work platforms (if available)		
ROPS/level 2 FOPS: relating to the standards for protective structures			

*The data given in this brochure are provided for information purposes and are subject to change without prior notice.
All images are purely guideline and might not give an exact representation of the product.
the stated weight refers to the vehicle unladen with standard equipment and may vary depending on the chosen configuration.

The standard machine configuration includes:

CAB

- “Easy access” system
- Comfort seat
- Adjustable steering column
- Analogue joypad
- Adjustable sunblind
- Heating
- Air conditioning
- FM/AM radio with USB and Bluetooth connectivity
- Ambient LED lights
- USB Type-A and Type-C (5 V) inputs

REAL TIME INFORMATION

- Touchscreen, 7”
- MCTS – Magni Combi Touch System on-board software
- Automatic RFID tools recognition system
- LMI – Load Moment Indicator
- LLD – Live Load Diagram
- Onboard and remote integrated diagnostics
- Reversing camera with image integrated in the MCTS

TECHNICAL SPECIFICATIONS

- Q-Fit standard
- Provision for platform
- Advanced three-line CAN BUS system
- Automatic levelling system for outriggers
- Automatic front and rear wheel alignment
- Standard turret rotation motor
- Automatic parking brake
- Mechanical battery cut-off in engine compartment
- Electrical system: 24 V – IP67

SERVICE

- MyMagni by Trackunit connectivity system (free of charge on request)
- Warranty: 24 months/2,000 hours