

# RTH 11.67



CONSTRUCTION



LOGISTICS

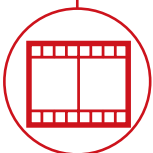

EVENTS AND  
FILM



**RTH**  
**11.67**



**CAB**

Best-in-class  
safety and visibility



**PERFORMANCE**

Unrivaled lifting  
performance



**LOAD LIVE DIAGRAM**

Three real-time dynamic  
load charts

# RTH 11.67

## DIMENSIONS (ft and in)

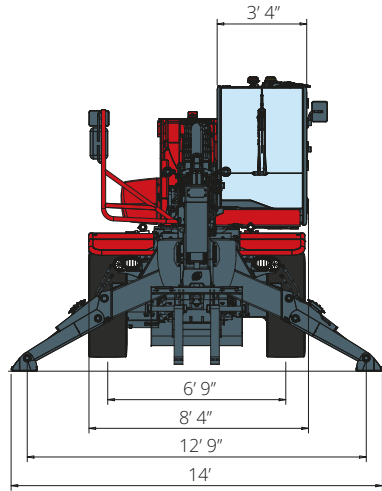

**FRONT**  
view

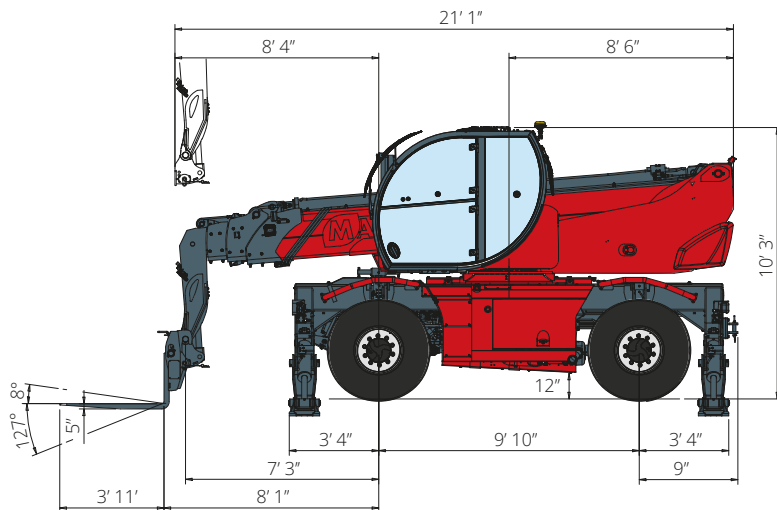

**SIDE**  
view

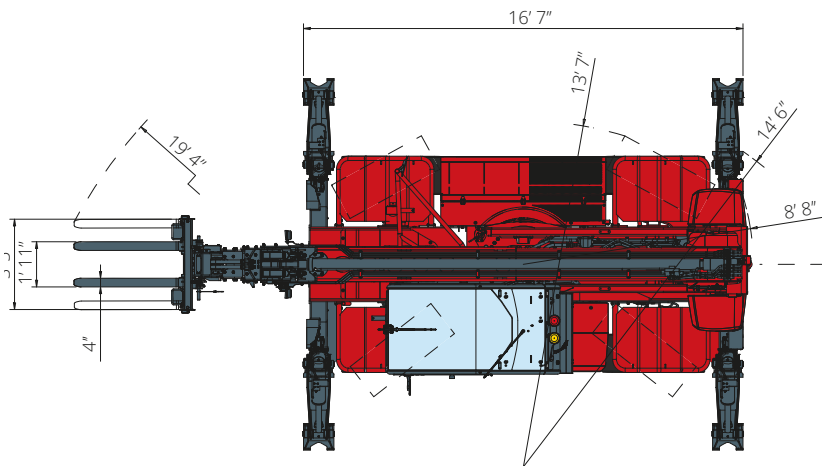

**TOP**  
view

Load chart with  
**FULLY EXTENDED STABILIZERS (360°)**

ATT - 03 - 001

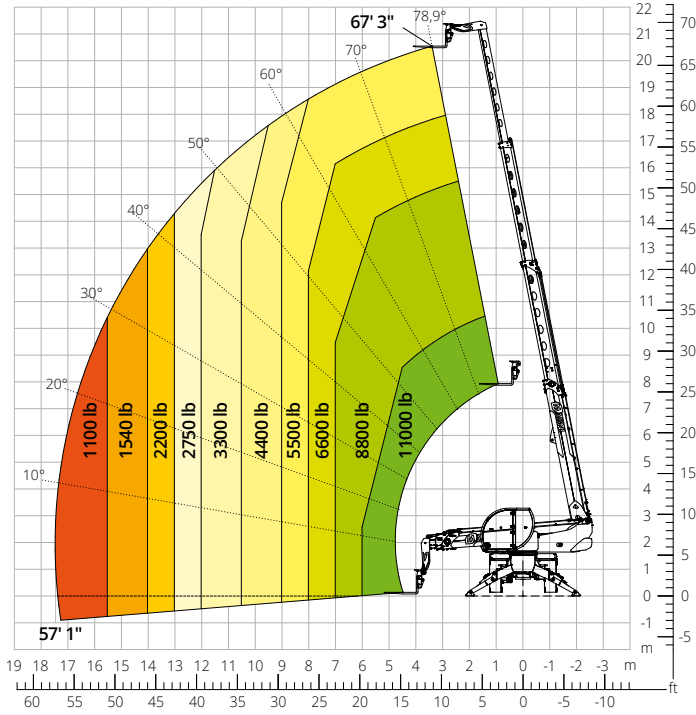

Load chart  
**FRONT ATTACHMENT ON TIRES**

ATT - 03 - 001

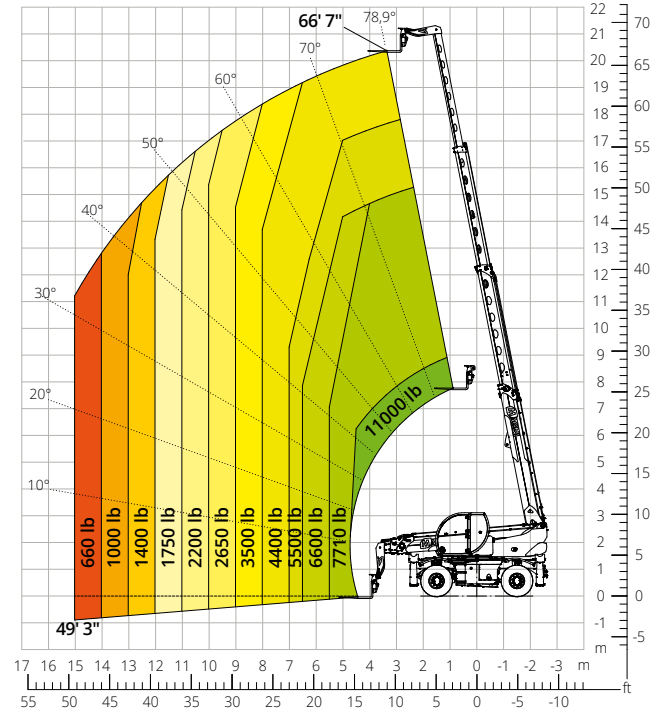

Load chart with  
**WINCH 7,700 lb**

ATT - 02 - 002

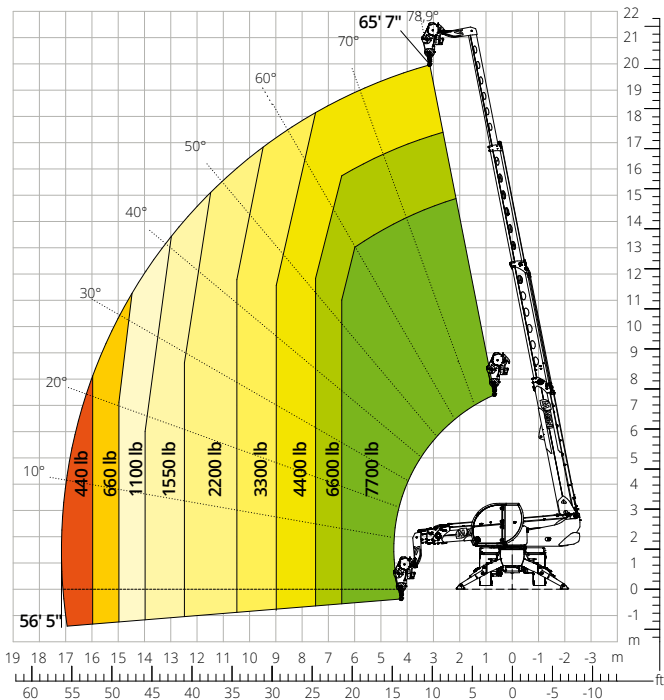

Load chart with  
**WINCH 11,000 lb**

ATT - 02 - 019

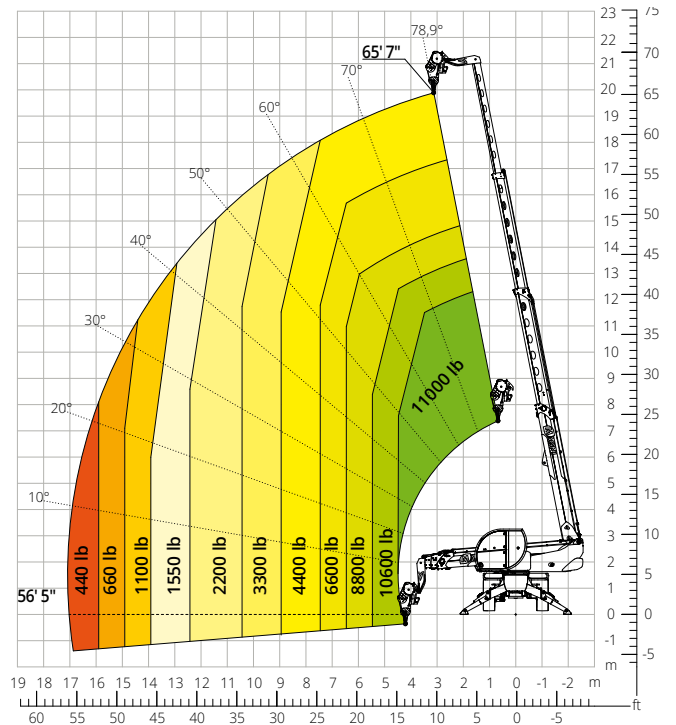

Load chart with  
**JIB WITH WINCH, 1,750 lb**  
 ATT - 04 - 005

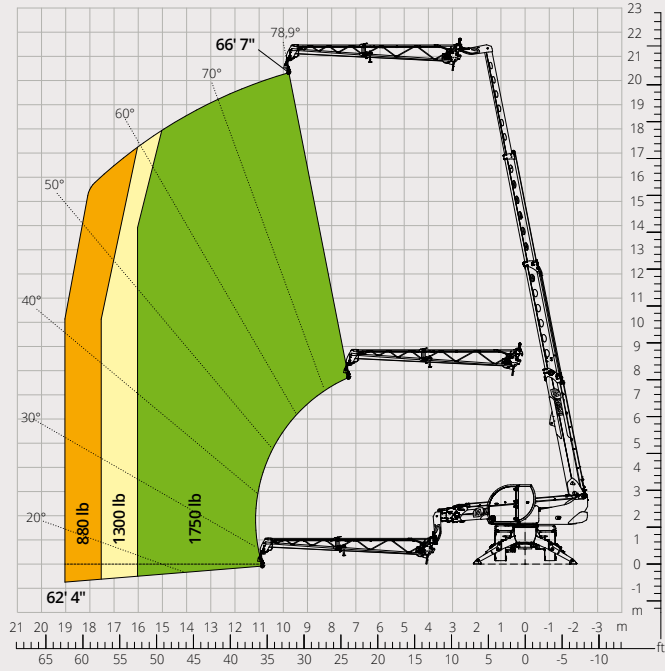

Load chart with  
**JIB WITH WINCH, 3,300 lb**  
 ATT - 04 - 011

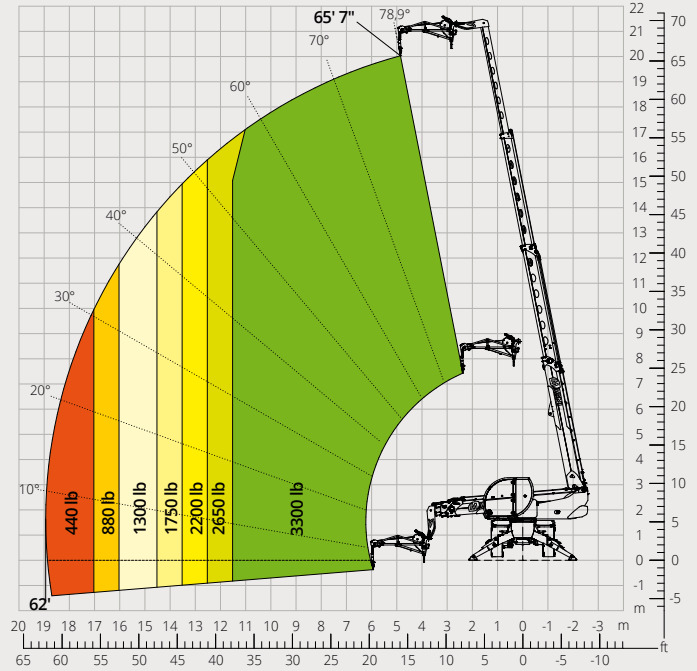

Load chart with  
**JIB WITH WINCH, 4,400 lb**  
 ATT - 04 - 015

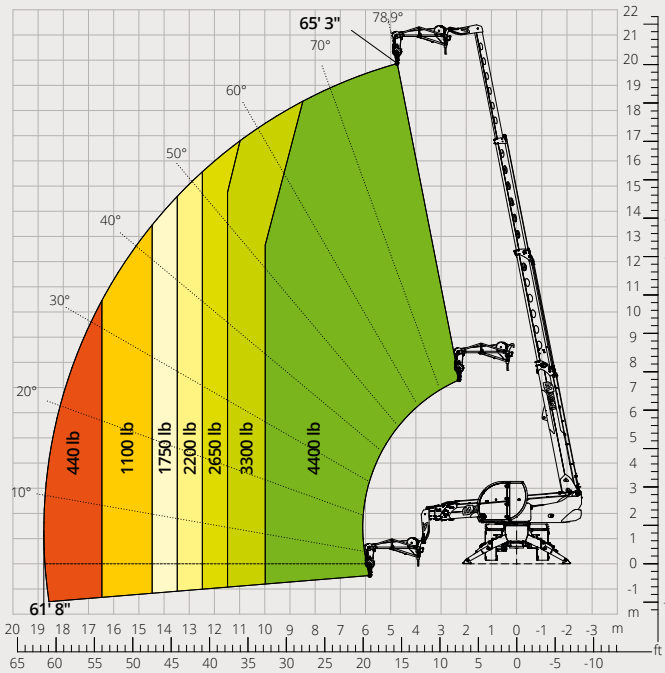

Load chart with  
**HOOK, 11,000 lb**  
 ATT - 05 - 014

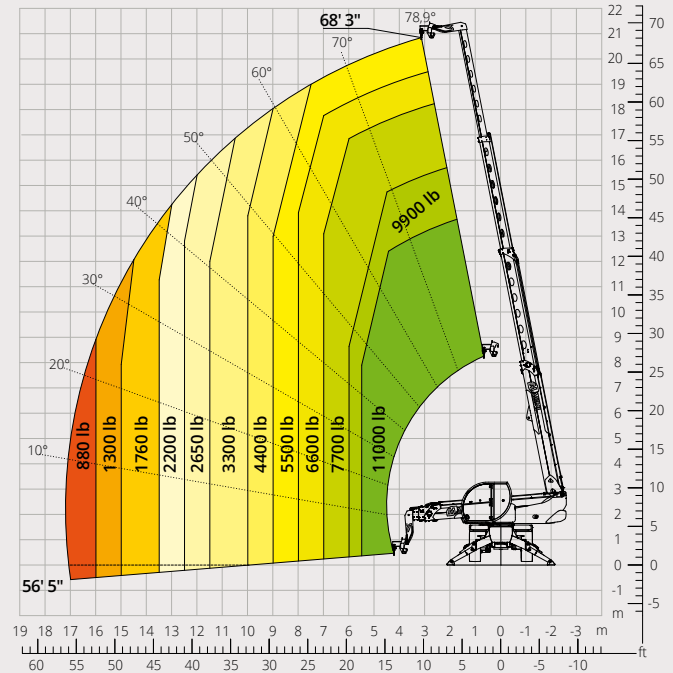

Load chart with  
**ROTATING EXTENDABLE PLATFORM 1,100 lb**  
 ATT - 01 - 005

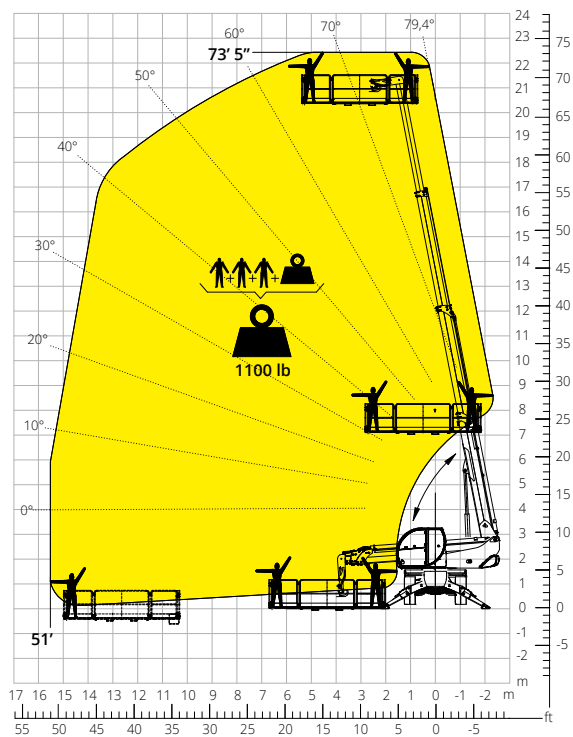

Load chart with  
**ROTATING EXTENDABLE PLATFORM 2,200 lb**  
 ATT - 01 - 016

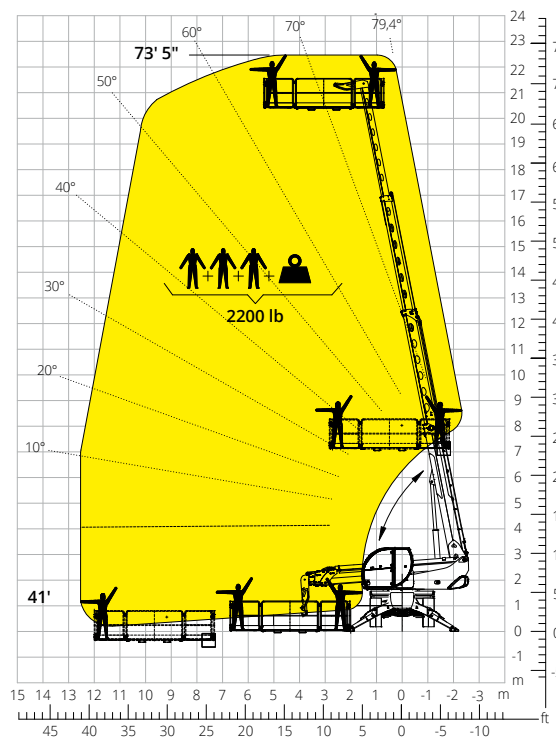

Load chart with  
**TELESCOPIC PLATFORM 440 lb - 32' 8"**  
 ATT - 01 - 022

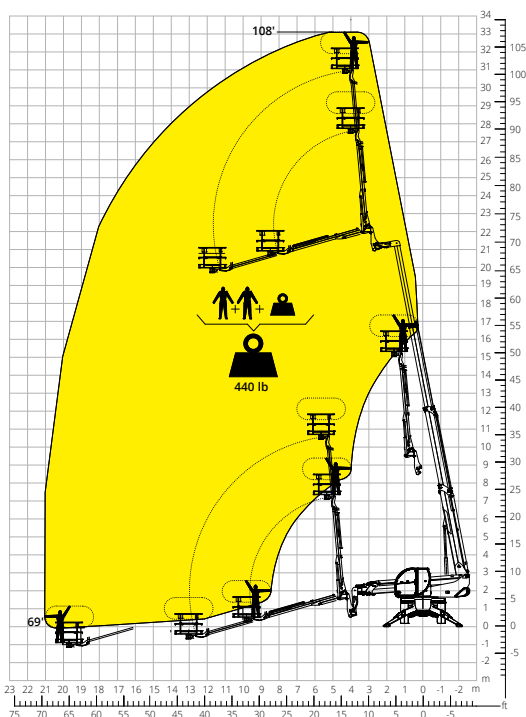

Load chart with  
**PLATFORM 1,100 lb WITH WINCH 1,300 lb**  
 ATT - 01 - 026

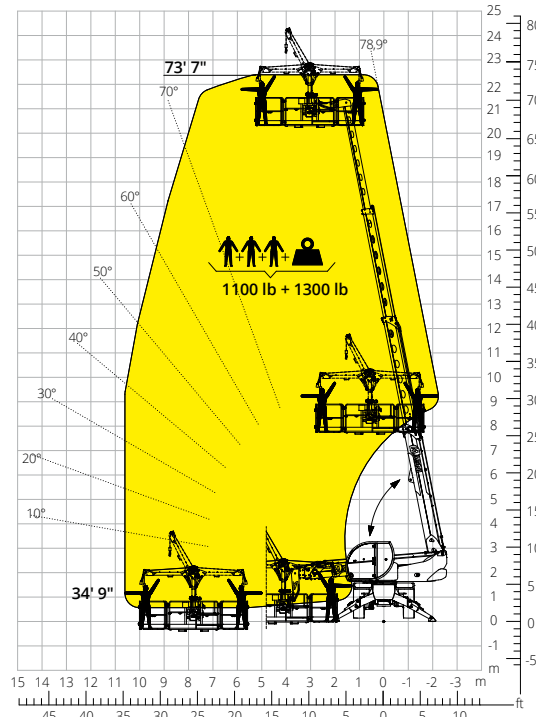

<b>Machine model</b>	Rotating telescopic handler	RTH 11.67	
	Maximum lifting capacity	11,000 lb	
	Maximum lifting height	67' 3"	
	Maximum reach	57' 1"	
	Rotation	360° (continuous)	
<b>Stabilizers</b>	Type	Pivoting	
<b>Engine</b>	Model	<b>Deutz TCD 3,6 L4 EDG Stage IIIA</b>	<b>Deutz TCD 3,6 L4 Stage V</b>
	Rated power	100 kW (136 hp) at 2,200 rpm	
	Maximum torque	369 lb/ft at 1,600 rpm	369 lb/ft at 1,600 rpm
	Displacement	220 in <sup>3</sup>	
	Cylinders	4 in line	
	Engine type	Turbocharged direct injection diesel	
	Cooling system	Water - intercooler	
<b>Transmission</b>	Type	Hydrostatic	
	Maximum pressure	480 bar	
	Gearbox	Dropbox, 2 speeds forward-reverse	
<b>Axles and brakes</b>	Type	Axles with planetary gearboxes	
	Front axle	Oscillating and steering with levelling, +/-8°	
	Rear axle	Oscillating and steering with hydraulic lock	
	No. of steering wheels	4WD - 4WS	
	Steering mode	Frontal/Concentric/Crab	
	Service brake	Wet multi-disk on front and rear axle	
	Parking brake	Hydraulic with negative action on front axle	
<b>Performance</b>	Tyre sizes	445/65 R22.5	
	Max. travel speed	25 mph	
	Gradeability (unladen)	44%	
	Turning radius (at forks)	19' 4"	
<b>Weights</b>	Total unladen*	35,050 lb	
<b>Tank and system capacities</b>	Diesel fuel	46.2 U.S. gal	46.2 U.S. gal
	AdBlue	-	2.64 U.S. gal
	Hydraulic fluid	28.3 U.S. gal	28.3 U.S. gal
	Engine oil	2.4 U.S. gal	2.4 U.S. gal
	Coolant	5.3 U.S. gal	5.3 U.S. gal
<b>Hydraulic circuit for movements</b>	Circuit type	Load sensing	
	Service pump	Variable displacement	
	Max. hydraulic flow rate	27.7 U.S. gpm	
	Max. boom head flow rate	19.8 U.S. gpm	
	Max. working pressure	350 bar	
	Distributor for boom and turret movements	SIL 2 electro-proportional valve	
Movements control	Dual joystick with integrated manoeuvre enable		
<b>Standards met</b>	2006/42/EC: EU Machinery Directive		
	2016/1628: EU Regulation on the emissions of stage V engines		
	EN 1459-X: Relating to standards on the safety requirements for variable reach machines		
	EN 280/EN 280-1/EN 280-2: standards relating to mobile elevating work platforms (if available)		
	ROPS/level 2 FOPS: relating to the standards for protective structures		

The data given in this brochure are provided for information purposes and are subject to change without prior notice.  
 All images are purely guideline and might not give an exact representation of the product.  
 \*the stated weight refers to the vehicle unladen with standard equipment and may vary depending on the chosen configuration.

## The standard machine configuration includes:

### CAB

- “Easy access” system
- Comfort seat
- Adjustable steering column
- Analogue joypad
- Adjustable sunblind
- Heating
- Air conditioning
- FM/AM radio with USB and Bluetooth connectivity
- Ambient LED lights
- USB Type-A and Type-C (5 V) inputs

### REAL TIME INFORMATION

- Touchscreen, 7”
- MCTS – Magni Combi Touch System on-board software
- Automatic RFID tools recognition system
- LMI – Load Moment Indicator
- LLD – Live Load Diagram
- Onboard and remote integrated diagnostics
- Reversing camera with image integrated in the MCTS

### TECHNICAL SPECIFICATIONS

- Q-Fit standard
- Provision for platform
- Advanced three-line CAN BUS system
- Automatic levelling system for outriggers
- Automatic front and rear wheel alignment
- Standard turret rotation motor
- Automatic parking brake
- Mechanical battery cut-off in engine compartment
- Electrical system: 24 V – IP67

### SERVICE

- MyMagni by Trackunit connectivity system (free of charge on request)
- Warranty: 24 months/2,000 hours