

HTH 26.31



MINING &
QUARRYING



HEAVY
LOGISTICS



DEFENSE



Machine model	Telescopic handler	HTH 26.31	
	Maximum lifting capacity	26,450 lb	
	Maximum lifting height	31'2"	
	Maximum reach	16'5"	
Engine	Model	Deutz TCD 3,6 L4-Stage V	Deutz TCD 3,6 L4-Stage IIIA
	Rated power	100 kW (136 hp) at 2,200 rpm	
	Maximum torque	369 lb/ft at 1.600 rpm	
	Displacement	219.7 in ³	
	Cylinders	4 in line	
	Engine type	Turbocharged direct injection common rail diesel	
	Cooling system	Water – intercooler	
Transmission	Type	Hydrostatic	
	Maximum pressure	450 bar	
	Gearbox	Dropbox, 2 speeds forward-reverse	
Axles and brakes	Type	Heavy-duty with planetary gearboxes	
	Front axle	Steering with levelling, +/-8°	
	Rear axle	Steering and oscillating	
	No. of driving - steering wheels	4WD - 4WS	
	Steering mode	Frontal/Concentric/Crab	
	Service brake	Servo-assisted pedal, acting on front and rear wheels	
	Parking brake	Hydraulic with negative action on front and rear axles	
Performance	Tire sizes	18 R22.5	
	Max. travel speed	25 mph	
	Gradeability (unladen)	63%	
Weights	Turning radius	12' 11"	
	Total unladen*	33,300 lb	
Tank and system capacities	Diesel fuel	52.8 U.S. gal	
	AdBlue	2.65 U.S. gal	
	Hydraulic fluid	55.48 U.S. gal	
	Engine oil	2.9 U.S. gal	
	Coolant	6.6 U.S. gal	
Hydraulic circuit for movements	Circuit type	Load sensing	
	Service pump	Variable displacement	
	Max. hydraulic flow rate	41.2 U.S. gpm	
	Max. boom head flow rate	19.9 U.S. gpm	
	Max. working pressure	350 bar	
	Distributor for boom movements	Proportional hydraulic distributor	
Standards met	Movements control	Multifunction electro-proportional joystick	
	2006/42/EC: EU Machinery Directive		
	2016/1628: EU Regulation on the emissions of stage V engines		
	EN 1459-X: Relating to standards on the safety requirements for variable reach machines		
	ROPS/level 2 FOPS: relating to the standards for protective structures		

*The data given in this brochure are provided for information purposes and are subject to change without prior notice.
All images are purely guideline and might not give an exact representation of the product.
the stated weight refers to the vehicle unladen with standard equipment and may vary depending on the chosen configuration.

Load chart
FRONT ATTACHMENT ON TIRES
 ATT-03-013

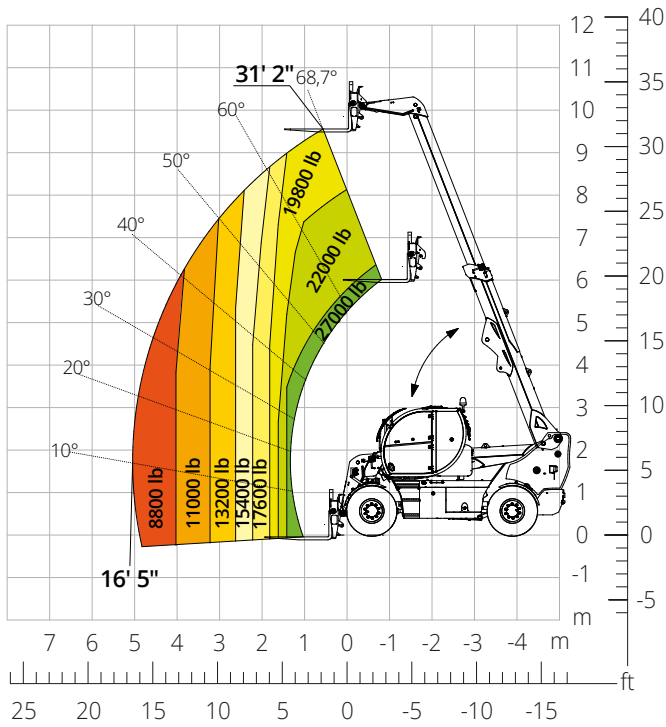

Load chart with
HOOK, 28,600 lb
 ATT-05-013

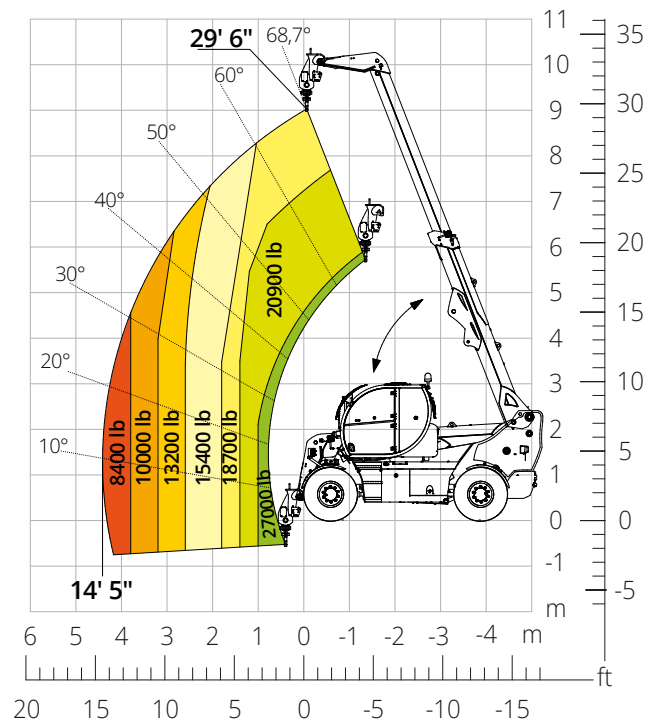

Load chart with
FORKS WITH POSITIONER, 27,000 lb
 ATT-03-050

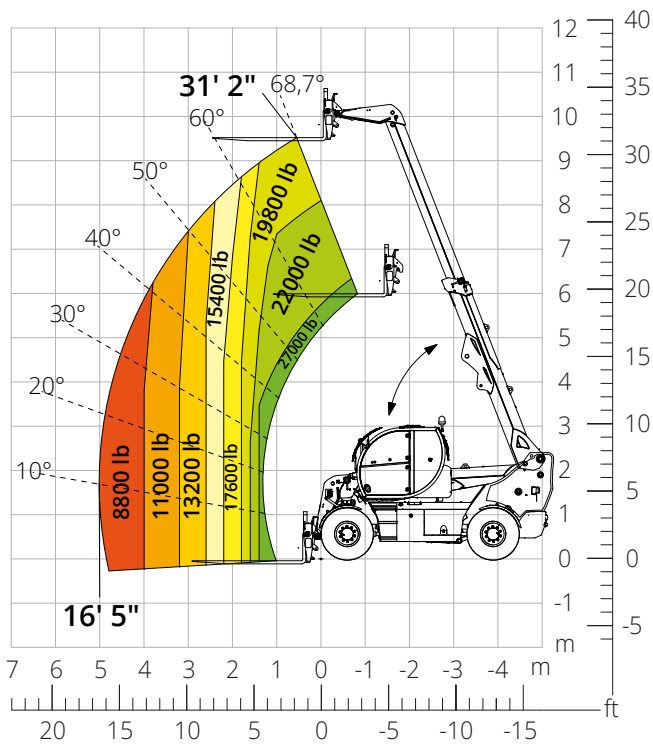

Load chart with
TIRE HANDLER, 8,400 lb
 ATT-06-005

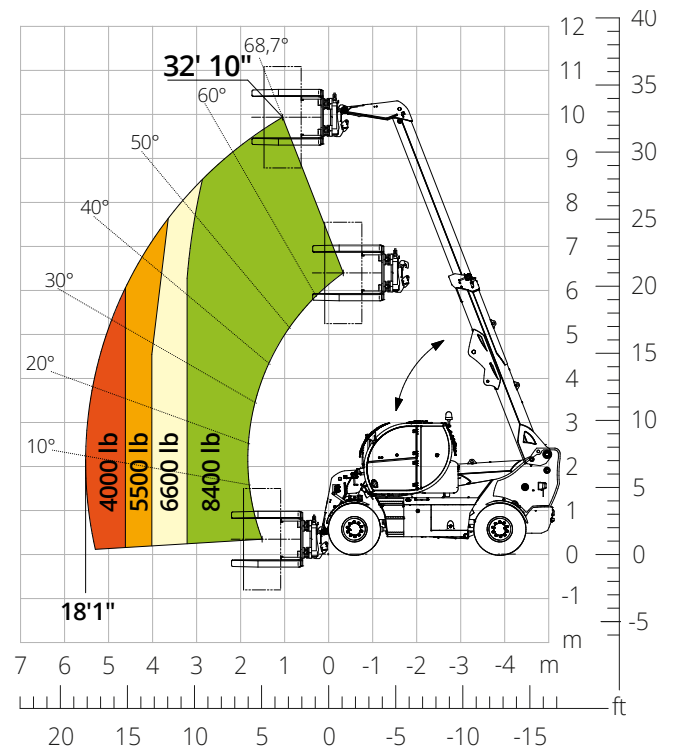

HTH 26.31



DIMENSIONS (ft and in)

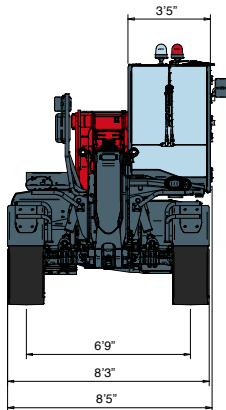

FRONT
view

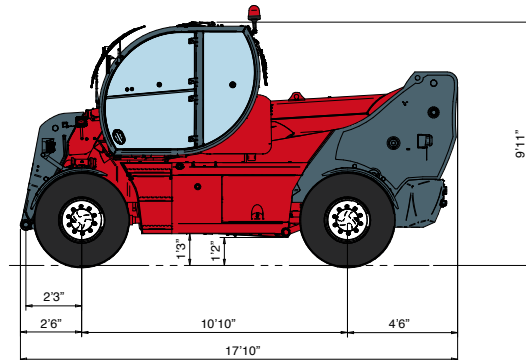

SIDE
view

TOP
view

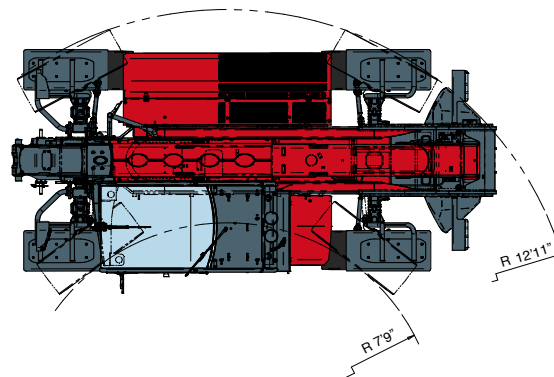

The standard machine configuration includes:

CAB

- Comfort seat
- Adjustable steering column
- Analogue joypad
- Heating
- Air conditioning
- FM/AM radio with USB and Bluetooth connectivity
- USB Type-A (5 V) inputs

REAL TIME INFORMATION

- Touchscreen, 7"
- MCTS – Magni Combi Touch System on-board software
- Automatic RFID tools recognition system
- LMI – Load Moment Indicator
- Onboard and remote integrated diagnostics

TECHNICAL SPECIFICATIONS

- Q-Fit Heavy-Duty
- Two-line CAN BUS system
- Automatic front and rear wheel alignment
- Automatic parking brake
- Mechanical battery cut-off in engine compartment
- Electrical system: 24 V – IP67

SERVICE

- MyMagni by Trackunit connectivity system (free of charge on request)
- Warranty: 24 months/2,000 hours